



VOLVO D13 / MACK MP8 SERIES

Basic Injector Sleeve Removal & Installation Manual
451-6681-50



IRONTITE PRODUCTS INC

2525 18th Str. SW, suite D, Cedar Rapids, Iowa 52404 USA
800-553-5953 · +1-319-377-9421 · www.ironite.com



**VOLVO D13 / MACK MP8 SERIES
INJECTOR SLEEVE REMOVAL & INSTALLATION
The VOLVO D13 / MACK MP8 Kit with Toolbox**



451-6681-50

Image #	Description	Part #
1	Sleeve Removal Tool	445-6682-10
2	Tip Expander Driver	445-6681-25
3	Tip Expander	445-6681-21
4	Permatex 64000 High Heat Sleeve Retainer	468-9640-00
5	Small Tip Bore Brush	450-6951-08
6	Tool Box	467-1950-25
7	Combo Large Brush-Upper Bore/Face	450-6951-07
8	Permatex Anti-Seize Lubricant	468-9771-34
N/A	Kit Instructions	451-3540-14

CONSUMABLES

Volvo D13 / Mack MP8 Stainless Steel Injector Sleeve w/O-Ring 419-6681-05

Made in USA

REMOVAL and INSTALLATION

Injector Sleeve Removal Instructions

Prerequisite: The cylinder head must be removed before starting this procedure.

Required Tool

- Removal Tool: **445-6682-10**
-

Procedure Steps

1. **Prepare the Tool:** Take the pilot tip of **Removal Tool 445-6682-10**.
2. **Insert Pilot Tip:** Insert the pilot tip into the **small opening** at the **combustion-chamber end** of the injector sleeve.
3. **Ensure Seating:** Verify that the pilot tip seats **fully** into the opening.
4. **Position the Tool:** Hold the removal tool **square** (perpendicular) to the injector sleeve.
5. **Remove the Sleeve:** While maintaining the square position, **tap the tool with a hammer** to drive the sleeve out.
 - **Note:** The sleeve will be driven out toward the **injector bore** (the top side of the cylinder head).

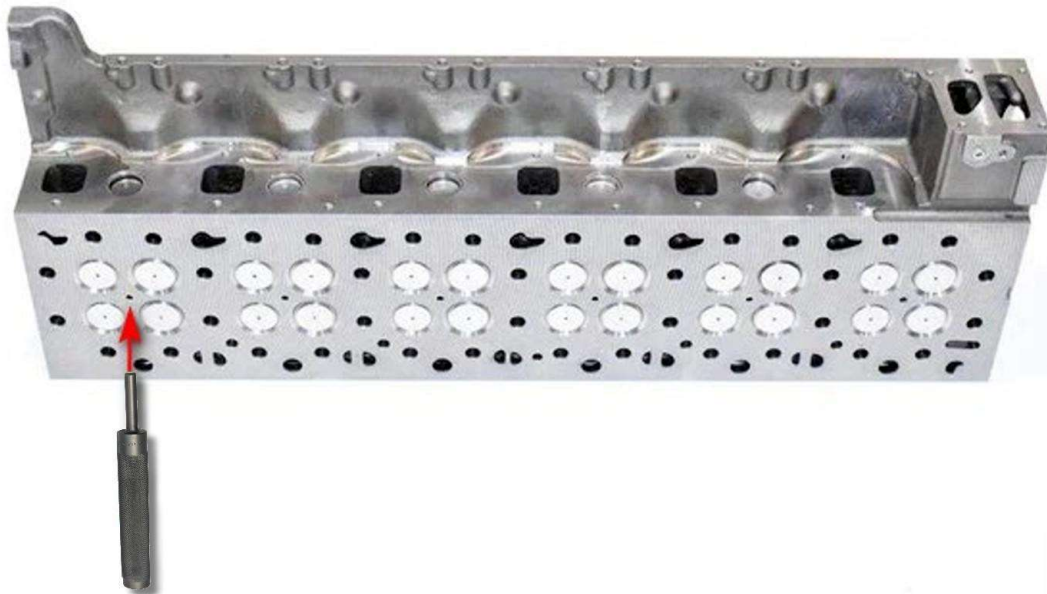

Sleeve Installation

1. Using the Combo Large Brush-Upper Bore/Face Brush (450-6951-07) clean the inside of the injector sleeve bore/face area.



2. Using the Small Tip Carbon Steel Bore Brush (450-6951-08) clean the tip of the injector sleeve bore area.



Sleeve Installation Continued

3. Install the O-ring onto the injector sleeve (419-6681-05).
 - Apply Permatex 64000 High Heat Sleeve Retainer (468-9640-00) to the lower end of the injector sleeve (419-6681-05).
 - Position the injector sleeve in the bore of the casting.
 - Using the tip expander driver (445-6681-25) and a hammer, drive the injector sleeve (419-6681-05) fully down until it seats at the bottom of the casting.

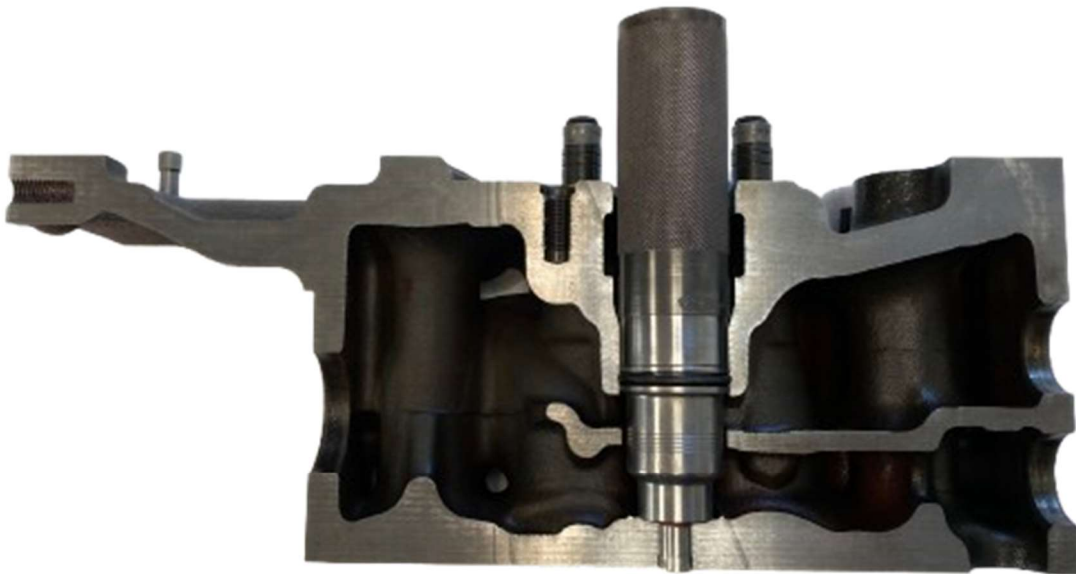

Sleeve Installation Continued

4. Assemble the tip expander driver (445-6681-25) with the tip expander (445-6681-21).
 - Apply Permatex anti-seize lubricant to the tip expander.
 - Position the tip expander at the nose of the injector sleeve.
 - Using a hammer, drive the tip expander through the nose of the injector sleeve.
 - From the combustion face of the cylinder head, remove the tip expander.
 - Remove the tip expander driver from the injector sleeve.

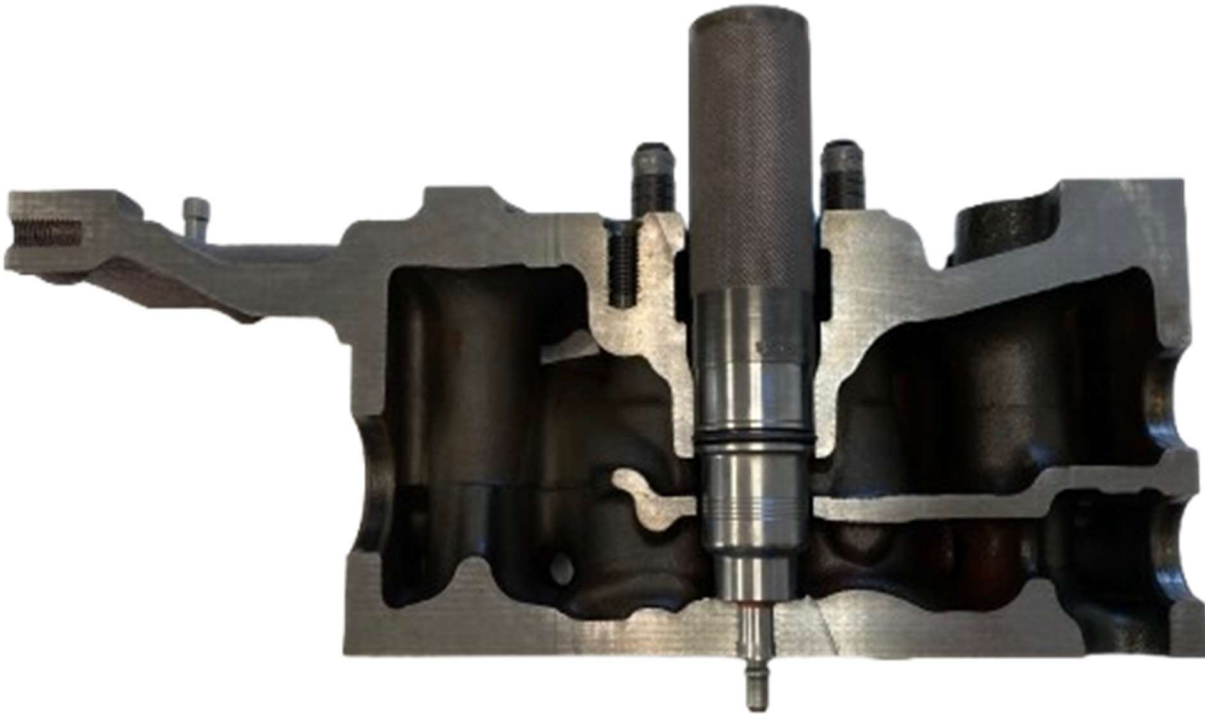

Irontite Products Inc.
2525 18th Street SW, Suite D, Cedar Rapids, IA 52404 USA
800-423-3384
+1-319-377-9421
FAX 319-377-9101
www.irontite.com

rev. 251118 · Doc. PN: 451-3540-14

A family of trusted brands for over 100 years.

