



ISX15 / QSX15 “SOHC” SERIES

SLEEVE REMOVAL & INSTALLATION INSTRUCTIONS



<u>ITEM #</u>	<u>DESCRIPTION</u>	<u>PART #</u>
	The Complete ISX15 / QSX15 SOHC Kit with Toolbox	450-6157-00
	<u>Kit includes the following:</u>	
1	Extended Tap	416-6156-60
2	Guide Bushing	416-6156-32
3	Injector Tube Clamp Assembly	416-6154-40
4	“T” Wrench 5/16”	467-1612-01
5	Sleeve Removal Tool	415-6136-00
6	Casting Cleaning Brush (Carbon Steel)	450-6951-01
7	Sleeve Drive in Tool	416-6157-51
8	Sleeve Roll-in Tool	416-6157-53
9	Irontite Tap & Lube	468-9910-08
10	Toolbox	467-1950-25

Tooling made in USA

Irontite Products Inc.

2525 18th Street SW, Suite D, Cedar Rapids, Iowa 52404
+1-319-377-9421 800-553-5953
www.irontite.com

Irontite Products Inc.

2525 18th Street SW, Suite D, Cedar Rapids, Iowa 52404
+1-319-377-9421 800-553-5953
www.irontite.com

REMOVAL and INSTALLATION

Sleeve Removal

- (1) With the valves removed, install the Injector Tube Clamp Assembly (416-6154-40) through the inside of the sleeve. Install the washer and the nut onto the stud sticking out from the face of the head and tighten with the T-Wrench (467-1612-01).
- (2) The Injector Tube Clamp Assembly is used to keep the sleeve from turning while tapping the sleeve in the following step.

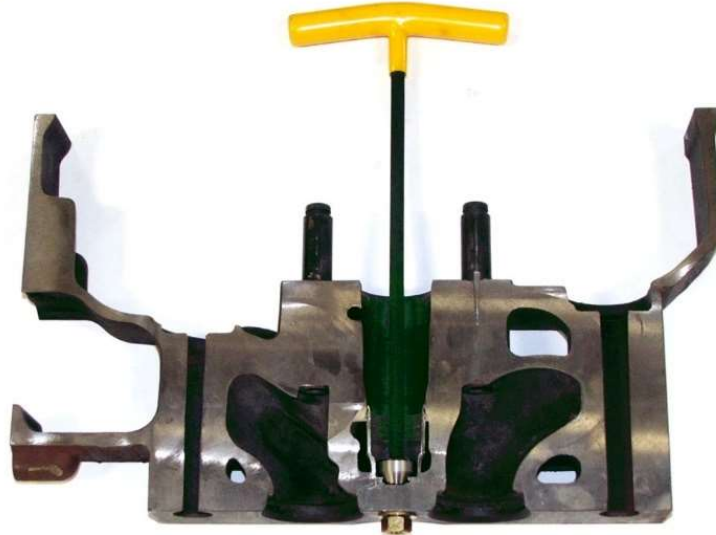

T-Wrench in Injector Tube Hold Down Assembly

- (3) Using the Extended Tap (416-6156-60) lubricated with Irontite Tap & Lube (468-9910-08) and the Guide Bushing (416-6156-32) tap the injector sleeve about 3/8" to 1/2" deep.
- (4) Unbolt and remove the Clamp Assembly.



Tap with Bushing & Injector Tube Hold Down Assembly

Irontite Products Inc.

2525 18th Street SW, Suite D, Cedar Rapids, Iowa 52404
+1-319-377-9421 800-553-5953

Page | 1

- (5) Insert the threaded puller shaft of the Sleeve Removal Tool (415-6136-00) down into the old sleeve using a $\frac{3}{4}$ " wrench on the top of the screw.
- (6) Continue to torque the shaft into the sleeve until the shaft grips the sleeve tightly with the threads.
- (7) Place the Bearing Guide Assembly over the Puller Shaft down against the face of the casting.
- (8) Screw on the Puller Cup down to the Bearing Guide Assembly. Continue turning the Puller Cup to remove the sleeve. If needed, you can use a $\frac{1}{2}$ " drive socket wrench placed into the top of the Puller Cap.

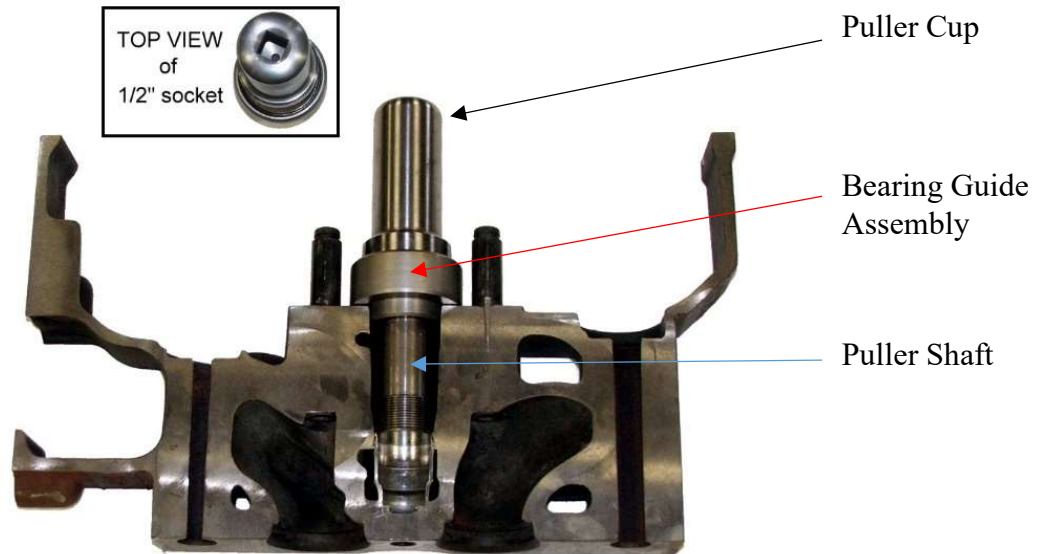

Sleeve Removal Tool

Irontite Products Inc.

2525 18th Street SW, Suite D, Cedar Rapids, Iowa 52404
+1-319-377-9421 800-553-5953

Sleeve Installation

1. Using the Carbon Steel Brush (450-6951-01) clean the inside of the injector sleeve bore.



Cleaning Brush after Sleeve Removal

2. Using the Sleeve Drive-In Tool (416-6157-51) and a hammer, drive the Injector "Sleeve" with O-Ring installed to the bottom of the casting.



Sleeve Drive-In Tool inserting new Sleeve

Irontite Products Inc.

2525 18th Street SW, Suite D, Cedar Rapids, Iowa 52404
+1-319-377-9421 800-553-5953

Page | 3

- Using the Sleeve Drive-In Tool (416-6157-51) and a hammer, drive the “Retaining Ring” to the bottom inside diameter of the Injector “Sleeve” to the casting.



Sleeve Drive-In Tool installing Retaining Ring

- The Sleeve Roll-In Tool (416-6157-53) is used to roll in the upper end of the injector sleeve. The Sleeve Roll-In Tool is used in a Machining Center (Seat & Guide Machine) and the tool needs to be kept lubricated with a “Quality Motor Oil” (NOT Irontite Tap & Lube). Roll in the upper end of the sleeve by running the machine clockwise and letting the Sleeve Roll-In Tool feed itself. To remove the tool, reverse the direction.



Roll-In Tool

Irontite Products Inc.

2525 18th Street SW, Suite D, Cedar Rapids, Iowa 52404
+1-319-377-9421 800-553-5953

Page | 4



IronTite Products Inc.

2525 18th Street SW, Suite D, Cedar Rapids, Iowa 52404

+1-319-377-9421 800-553-5953

www.ironTite.com

DOC#: 451-3550-02 REV: 160816